

User Benefits

- High efficiency
- Low energy consumption
- Compact size
- Robust construction
- Smooth flow
- Reversible operation
- Low shear pumping
- Minimal pumped media agitation
- Hygienic design
- Easy maintenance

Series S



Rotary Lobe Pumps for all applications

SSP brand Series S stainless steel rotary lobe pumps, from Alfa Laval Pumps Limited, operate at the heart of process industries worldwide. Series S pumps fulfill a wide range of application requirements throughout Chemical, Food, Pharmaceutical and other related industries.

Handling from low to high viscosity pumped media the characteristic smooth, low shear pumping action is ideal for delicate media and where organic solids in suspension, creams, froths, gels, emulsions and mixtures are to be pumped.

Series S pumps are suitable for CIP (Cleaning In Place) and conform to USA 3A Sanitary Standard.

Operation

The positive displacement of the Series S pump is provided by non-contacting, counter rotating tri-lobe or bi-lobe rotors within a fully swept pump chamber. All Series S pumps are capable of bi-rotational flow without modification.

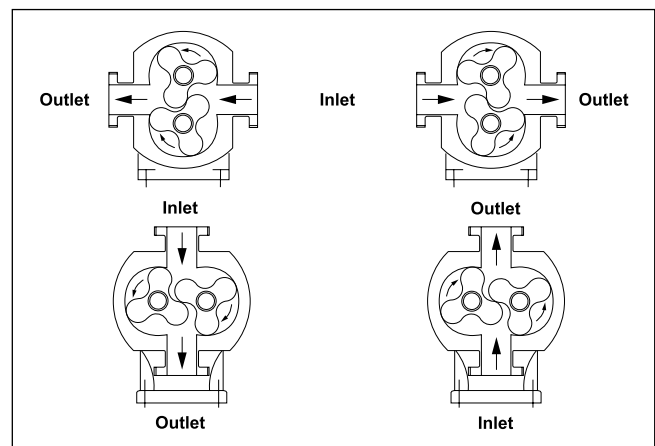

Performance

The Series S pump range has twelve pump head displacements ranging from 1.4 gallons/100 revs to 93.26 gallons/100 revs.

- Flow rates up to 466 gpm
- Differential pressures up to 290 psi
- Port sizes from 1" to 6" diameter

High Volumetric Efficiency - The Series S pump offers high efficiency transfer of low, medium and high viscosity pumped media. This important aspect of performance is achieved by maintaining high accuracy and repeatability of component part manufacture, thereby maximizing shaft rigidity and minimizing the effects of thermal expansion within the pump gearbox. This combination allows the optimum pump head geometry to be achieved which, in turn, maximizes volumetric efficiency.

Low NPSH - The Series S pump with standard port connections has full through-bore inlet and outlet ports to International Standards. This reduces inlet and outlet port losses, thereby lowering NPSH requirements.

Basic Design

The Series S pump with its modular design giving a choice of 44 models, provides for greater application flexibility and cost effective easy maintenance.

Pumphead - All metallic pumped media wetted components are manufactured in 316L type stainless steel. The Series S in standard specification has tri-lobe rotors available in three temperature ratings, allowing the pump to be operated at maximum temperatures of 158°F, 266°F and 392°F for both process and CIP.

Shafts - 316L Stainless steel shafts are used for pressures up to 145 psi. Higher pressures up to 290 psi are attained by the use of high strength duplex stainless steel.

Gearbox - The Series S pump has a robust cast iron gearbox with a universal design for models S1 to S4. This gives the flexibility of mounting pumps with the inlet and outlet ports in either a vertical or horizontal plane by changing the foot and its position. The Series S models S5 and S6 have a choice of two dedicated gearbox castings, which allows the inlet and outlet ports to be in either the vertical or horizontal plane.

Pump Model	Inlet and Outlet Connections		Displacement US gal/100 revs	Differential Pressure psi	Maximum Speed rev/min	Weight Bare Shaft Pump	
	Standard Port Connection Size inches	Enlarged Port Connection Size inches				Horizontal Porting (H) lb	Vertical Porting (V) lb
S1-0005-*08	1.00	-	1.4	115	1000	33	36
S1-0008-*05	1.00	1.50	2.25	75	1000	38	40
S2-0013-*10	1.00	1.50	3.38	145	1000	62	67
S2-0013-*15	1.00	1.50	3.38	215	1000	62	67
S2-0018-*07	1.50	2.00	4.78	100	1000	64	69
S2-0018-*10	1.50	2.00	4.78	145	1000	64	69
S3-0027-*10	1.50	2.00	7.03	145	1000	117	124
S3-0027-*15	1.50	2.00	7.03	215	1000	117	124
S3-0038-*07	2.00	2.50	10.15	100	1000	124	130
S3-0038-*10	2.00	2.50	10.15	145	1000	124	130
S4-0055-*10	2.00	2.50	14.64	145	1000	232	245
S4-0055-*20	2.00	2.50	14.64	290	1000	232	245
S4-0079-*07	2.50	3.00	20.87	100	1000	243	256
S4-0079-*15	2.50	3.00	20.87	215	1000	243	256
S5-0116-*10	2.50	3.00	30.65	145	600	335	335
S5-0116-*20	2.50	3.00	30.65	290	600	335	335
S5-0168-*07	3.00	4.00	44.39	100	600	353	353
S5-0168-*15	3.00	4.00	44.39	215	600	353	353
S6-0260-*10	4.00	4.00	68.70	145	500	574	574
S6-0260-*20	4.00	4.00	68.70	290	500	574	574
S6-0353-*07	4.00	6.00	93.26	100	500	585	585
S6-0353-*15	4.00	6.00	93.26	215	500	585	585

* = H or V

H = Horizontal Porting

V = Vertical Porting

Specification Options



Pump overload protection

For essential overload protection to protect pump, drive unit and also limit pressure build up within associated process equipment.

Pressure relief valve - supplied as an integral part of the pump and not requiring any external pipework. The design is such that the valve mechanism is isolated from the pumped media. Mechanical or pneumatic operation is available for both pressure/safety and cleaning bypass.

Pump Protection Unit (PPU) - supplied as an alternative to mechanical relief valves. Incorporating micro-controller technology the PPU detects and reacts to changes in load conditions.

Surface finish and coatings

To enhance standard surface finish or for hygiene purposes, the pumphead and rotors may be electro polished. For abrasive applications the stainless steel pumphead and rotors may be supplied with a tungsten carbide coating or other surface hardening treatment to increase wear resistance.

Interchangeable rotors

Mathematically defined profile and precision manufacture ensure interchangeability of rotors with sealed involute splines giving accurate position, location and positive rotor drive.

Option of bi-lobe rotors in stainless steel for handling products containing large delicate solids, or bi-lobe rotors manufactured from non-galling alloy for increased efficiencies. Elastomeric tri-lobe rotors can also be offered where the application dictates.

Pumped media seals

The optimum primary seal can be chosen to match the pumped media and duty conditions. Single or double mechanical seals include flushed or aseptic variants. For arduous duties hard faced seal materials such as tungsten carbide or silicon carbide can be used. Packed glands offer a simple, low cost, and easy to maintain controlled leakage sealing arrangement.

Pumped media wetted elastomers are EPDM, NBR, FPM all FDA conforming or PTFE for chemical applications.

Heating / Cooling devices

These are primarily used for heating the pumphead so as to maintain the pumped media viscosity and reduce risk of any crystallization/ solidification. They may also be used for cooling purposes when required.

Connections

Comprehensive choice covering

- Screwed male connections to all major standards including BSP, DIN11851, IMDA/3A, ISS/IDF, NPT, Rdg, RJT, SMS, Tri-clamp and more.
- Flange connections to all major standards including ASA/ANSI150, BS4504/DIN2533, BS10E and more.
- Enlarged diameter and rectangular ports for handling very high viscosity products.

Motorized pump units

Pumps may be supplied fully motorized with fixed or variable speed drives including appropriate control systems if required, mounted on either mild or stainless steel baseplates.

In addition to electric motor drives, hydraulic, pneumatic, diesel or gasoline powered prime movers can be fitted.

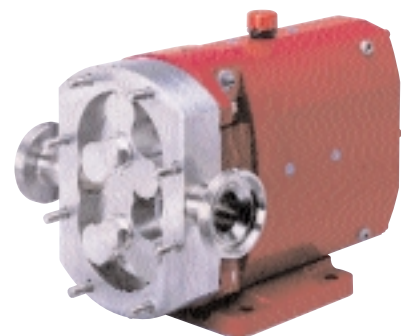

Bareshaft Pump Dimensions

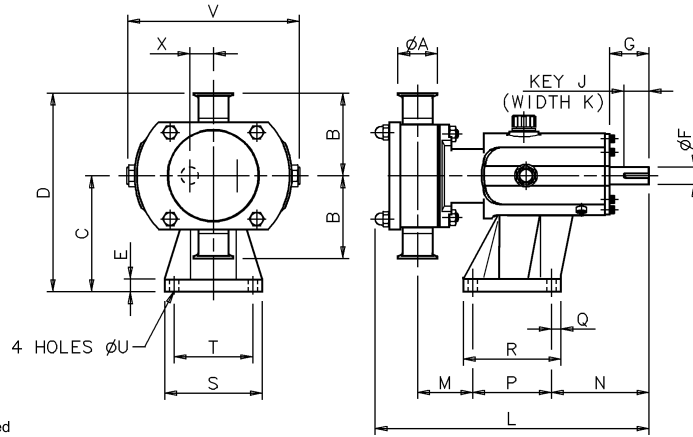

Vertically ported (V)

All dimensions in inches, unless otherwise noted

Pump Model	A		B	C	D	E	F (mm)	G	J (mm)	K (mm)	L	M	N	P	Q	R	S	T	U	V	X
	Standard Port	Enlarged Port																			
S1-0005-V08	1.00	-	3.74	4.45	8.19	0.59	16	1.57	30	5	11.22	1.93	4.61	3.15	0.87	4.49	4.09	3.15	0.39	7.05	0.89
S1-0008-V05	1.00	1.50	3.74	4.45	8.19	0.59	16	1.57	30	5	11.61	2.17	4.61	3.15	0.87	4.49	4.09	3.15	0.39	7.05	0.89
S2-0013-V10 or V15	1.00	1.50	4.13	5.79	9.92	0.59	22	1.97	32	6	13.35	2.64	4.88	3.94	0.47	4.88	4.88	3.94	0.47	8.62	1.18
S2-0018-V07 or V10	1.50	2.00	4.13	5.79	9.92	0.59	22	1.97	32	6	13.70	2.76	4.88	3.94	0.47	4.88	4.88	3.94	0.47	8.62	1.18
S3-0027-V10 or V15	1.50	2.00	4.92	6.89	11.81	0.87	28	2.40	40	8	17.20	2.66	6.34	6.10	0.59	7.28	6.10	4.92	0.55	9.96	1.48
S3-0038-V07 or V10	2.00	2.50	4.92	6.89	11.81	0.87	28	2.40	40	8	17.72	2.83	6.34	6.10	0.59	7.28	6.10	4.92	0.55	9.96	1.48
S4-0055-V10 or V20	2.00	2.50	5.91	8.39	14.29	0.98	38	3.15	63	10	21.30	3.07	7.76	7.87	0.67	9.21	7.24	5.91	0.55	12.09	1.89
S4-0079-V07 or V15	2.50	3.00	5.91	8.39	14.29	0.98	38	3.15	63	10	21.97	3.43	7.76	7.87	0.67	9.21	7.24	5.91	0.55	12.09	1.89
S5-0116-V10 or V20	2.50	3.00	6.89	10.10	16.99	1.18	45	4.33	70	14	24.69	3.60	10.39	7.87	0.79	9.45	8.66	7.09	0.55	13.58	2.36
S5-0168-V07 or V15	3.00	4.00	6.89	10.10	16.99	1.18	45	4.33	70	14	25.59	4.06	10.39	7.87	0.79	9.45	8.66	7.09	0.55	13.58	2.36
S6-0260-V10 or V20	4.00	4.00	7.48	11.61	19.09	1.18	48	4.33	70	14	29.45	4.88	10.51	10.24	0.79	11.81	9.84	8.27	0.55	15.75	2.76
S6-0353-V07 or V15	4.00	6.00	7.48	11.61	19.09	1.18	48	4.33	70	14	30.59	5.47	10.51	10.24	0.79	11.81	9.84	8.27	0.55	15.75	2.76

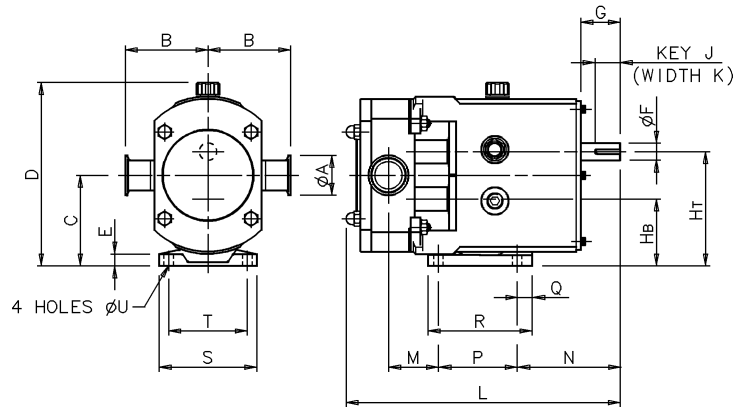

Horizontally ported (H)

All dimensions in inches, unless otherwise noted

Pump Model	A		B	C	D	E	F (mm)	G	HB	HT	J (mm)	K (mm)	L	M	N	P	Q	R	S	T	U
	Standard Port	Enlarged Port																			
S1-0005-H08	1.00	-	3.74	3.56	7.44	0.39	16	1.57	2.68	4.45	30	5	11.22	1.65	4.88	3.15	0.39	3.94	3.94	3.15	0.39
S1-0008-H05	1.00	1.50	3.74	3.56	7.44	0.39	16	1.57	2.68	4.45	30	5	11.61	1.89	4.88	3.15	0.39	3.94	3.94	3.15	0.39
S2-0013-H10 or H15	1.00	1.50	4.13	4.53	9.17	0.59	22	1.97	3.35	5.71	32	6	13.35	2.36	5.16	3.94	0.75	5.20	4.88	3.94	0.47
S2-0018-H07 or H10	1.50	2.00	4.13	4.53	9.17	0.59	22	1.97	3.35	5.71	32	6	13.70	2.48	5.16	3.94	0.75	5.20	4.88	3.94	0.47
S3-0027-H10 or H15	1.50	2.00	4.92	5.41	10.75	0.71	28	2.40	3.94	6.89	40	8	17.20	3.25	6.93	4.92	1.18	7.13	6.06	4.92	0.55
S3-0038-H07 or H10	2.00	2.50	4.92	5.41	10.75	0.71	28	2.40	3.94	6.89	40	8	17.72	3.43	6.93	4.92	1.18	7.13	6.06	4.92	0.55
S4-0055-H10 or H20	2.00	2.50	5.91	6.42	12.80	0.79	38	3.15	4.53	8.31	63	10	21.30	3.98	8.82	5.91	1.38	7.95	7.24	5.91	0.55
S4-0079-H07 or H15	2.50	3.00	5.91	6.42	12.80	0.79	38	3.15	4.53	8.31	63	10	21.97	4.33	8.82	5.91	1.38	7.95	7.24	5.91	0.55
S5-0116-H10 or H20	2.50	3.00	6.89	7.68	14.80	0.79	45	4.33	5.31	10.04	70	14	24.69	3.82	10.98	7.09	1.38	10.83	8.27	7.09	0.55
S5-0168-H07 or H15	3.00	4.00	6.89	7.68	14.80	0.79	45	4.33	5.31	10.04	70	14	25.59	4.25	10.98	7.09	1.38	10.83	8.27	7.09	0.55
S6-0260-H10 or H20	4.00	4.00	7.48	8.86	16.89	0.79	48	4.33	6.10	11.61	70	14	29.45	4.90	10.47	10.24	1.57	14.57	8.66	7.48	0.55
S6-0353-H07 or H15	4.00	6.00	7.48	8.86	16.89	0.79	48	4.33	6.10	11.61	70	14	30.59	5.51	10.47	10.24	1.57	14.57	8.66	7.48	0.55

Tel: 877-476-3569

478-471-7327

Fax: 877-471-3569

Email: flow@gmpump.com

www.gmpump.com



PUMPS Inc.

The information contained herein is correct at the time of issue, but may be subject to change without prior notice

Ref: SVI/0103. Printed in England.